

PerformancePro Pumps Engineering Data Packet

Pump:

Series: Cascade High Speed
Pump Model: C1/3
Design: Flooded Suction
Inlet: 1.5 inch
outlet: 1.5 inch
Impeller: CN1/3
Trim: 4.80
Fluid: Water

Motor:

Motor Number: CPM-121
Manufacturer: Baldor
Rated HP: 0.60
Total HP: 0.60
Speed: 3450
Enclosure: ODP
Frame: 56J (Jet Pump)
Volts: 115/208-230
Phase: 1
Frequency: 60
Amps At Total HP: 5.2/2.8-2.6

C1/3

— Head (FT) - - - Power (Watts)

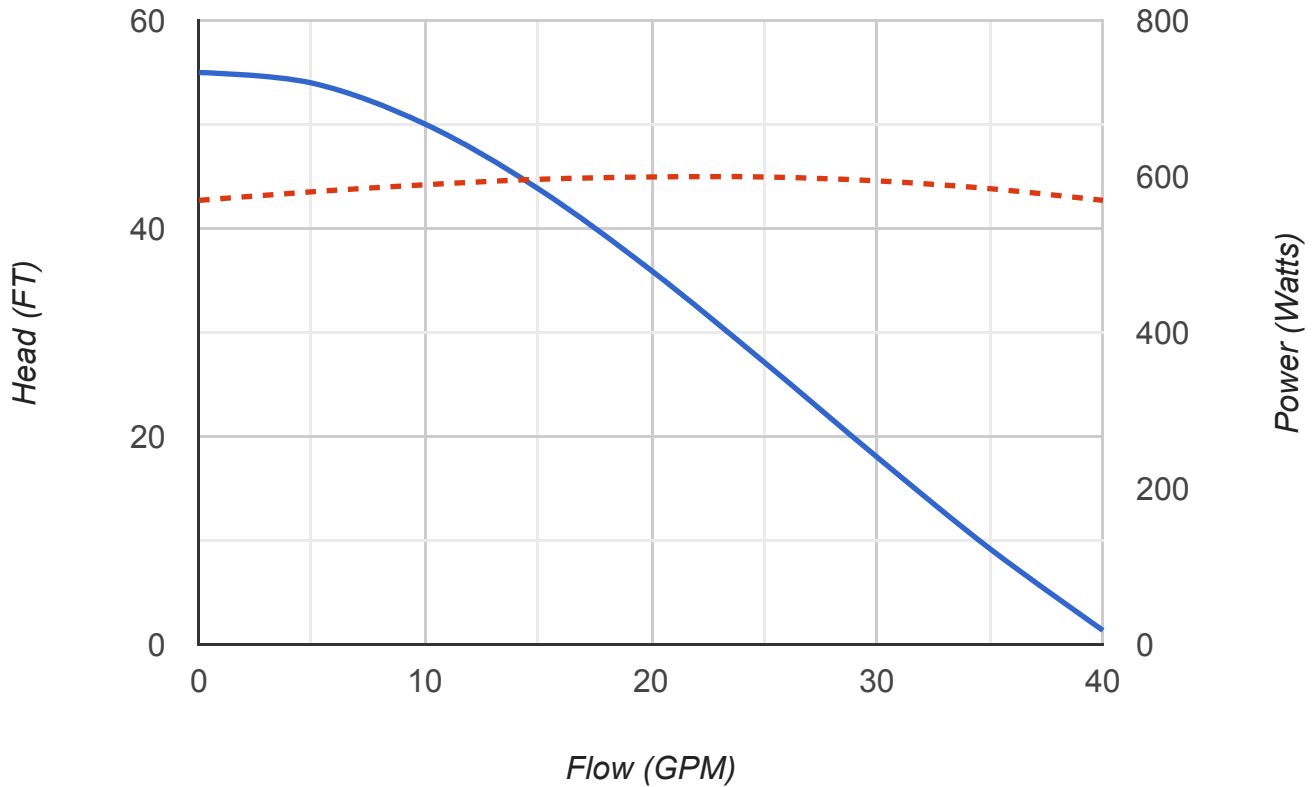

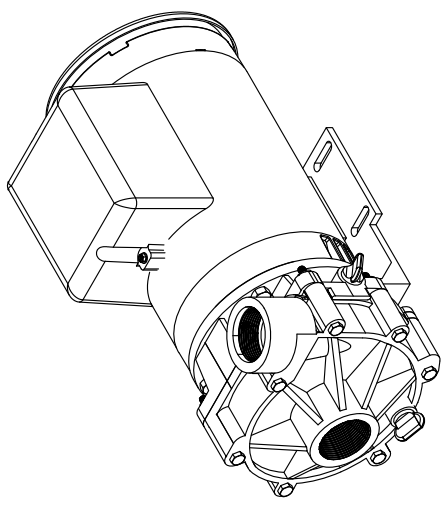
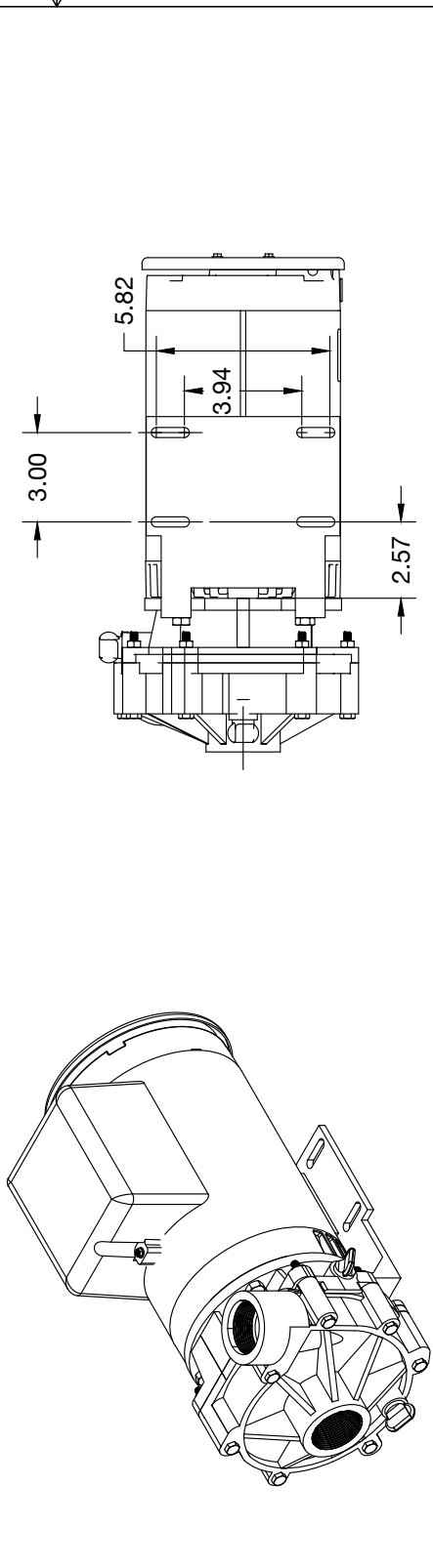
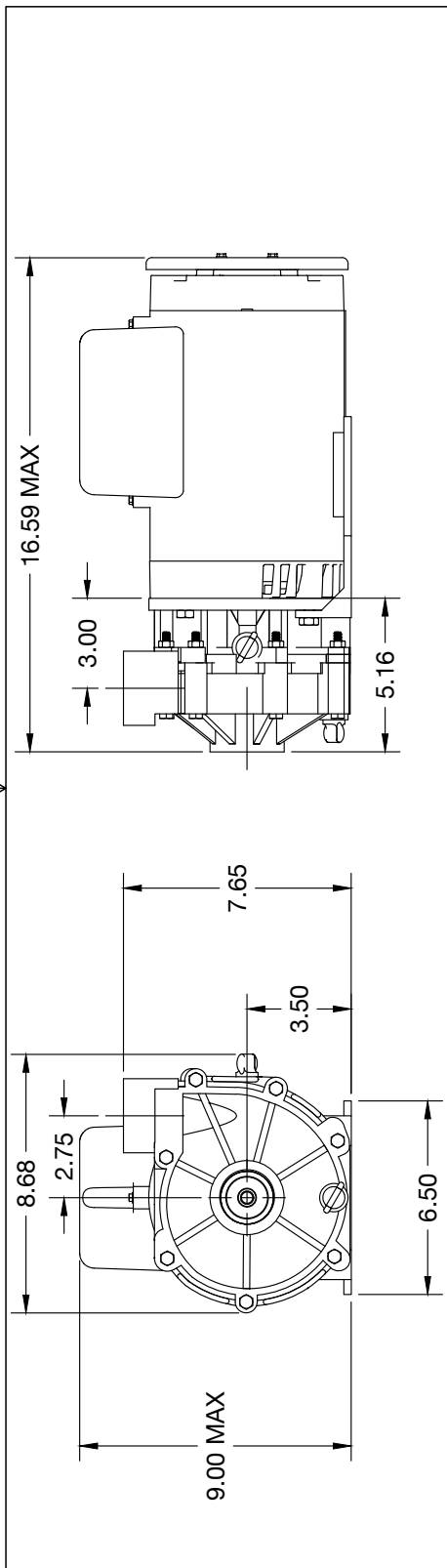

PerformancePro <small>PROVEN BUILT IN THE USA SINCE 2000</small>		Cascade High Speed	
PUMPS		T.H.P.: 0.6HP THRU 2.5HP	
Greg Gent	1:5	3/29/21	C1D001412
			00

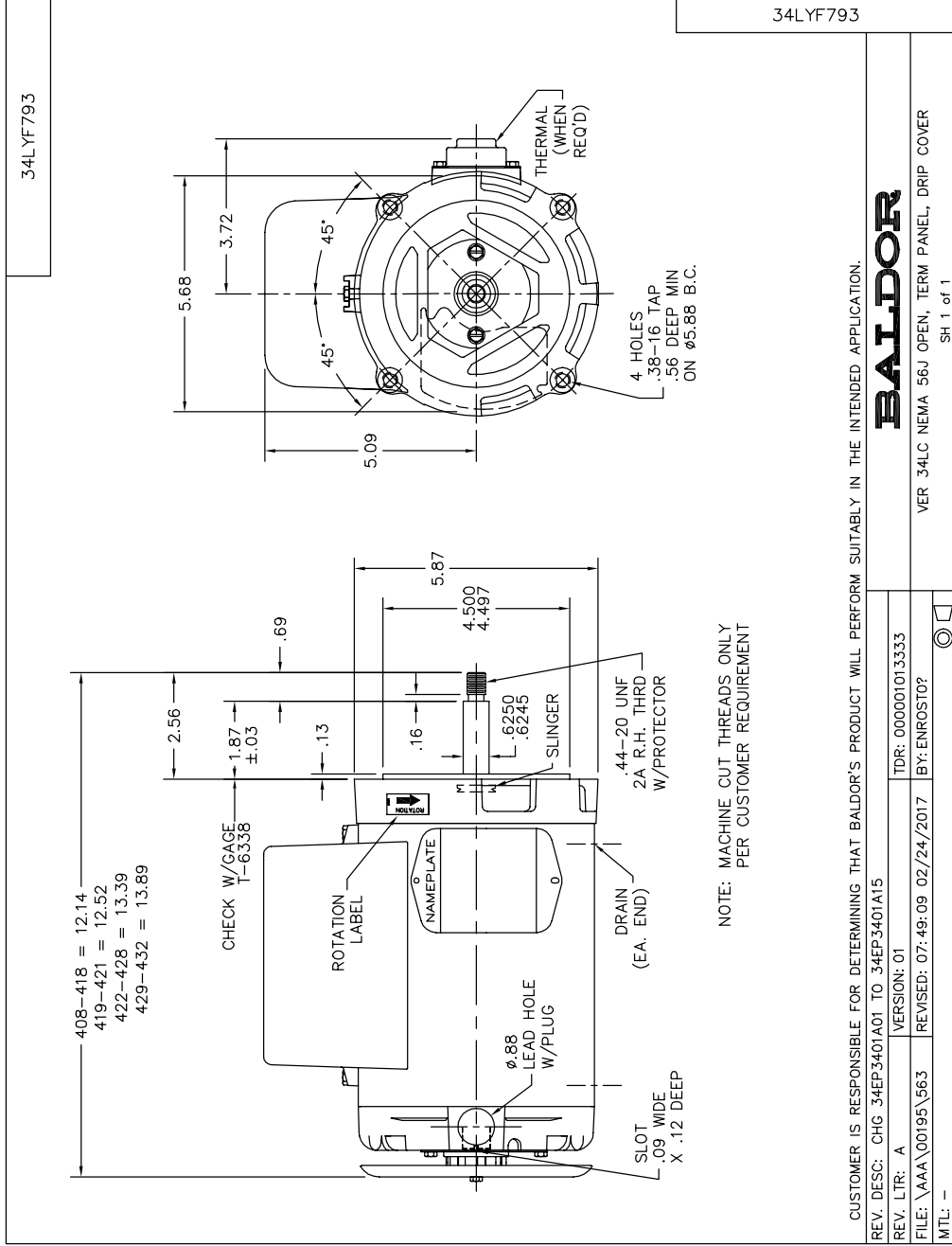

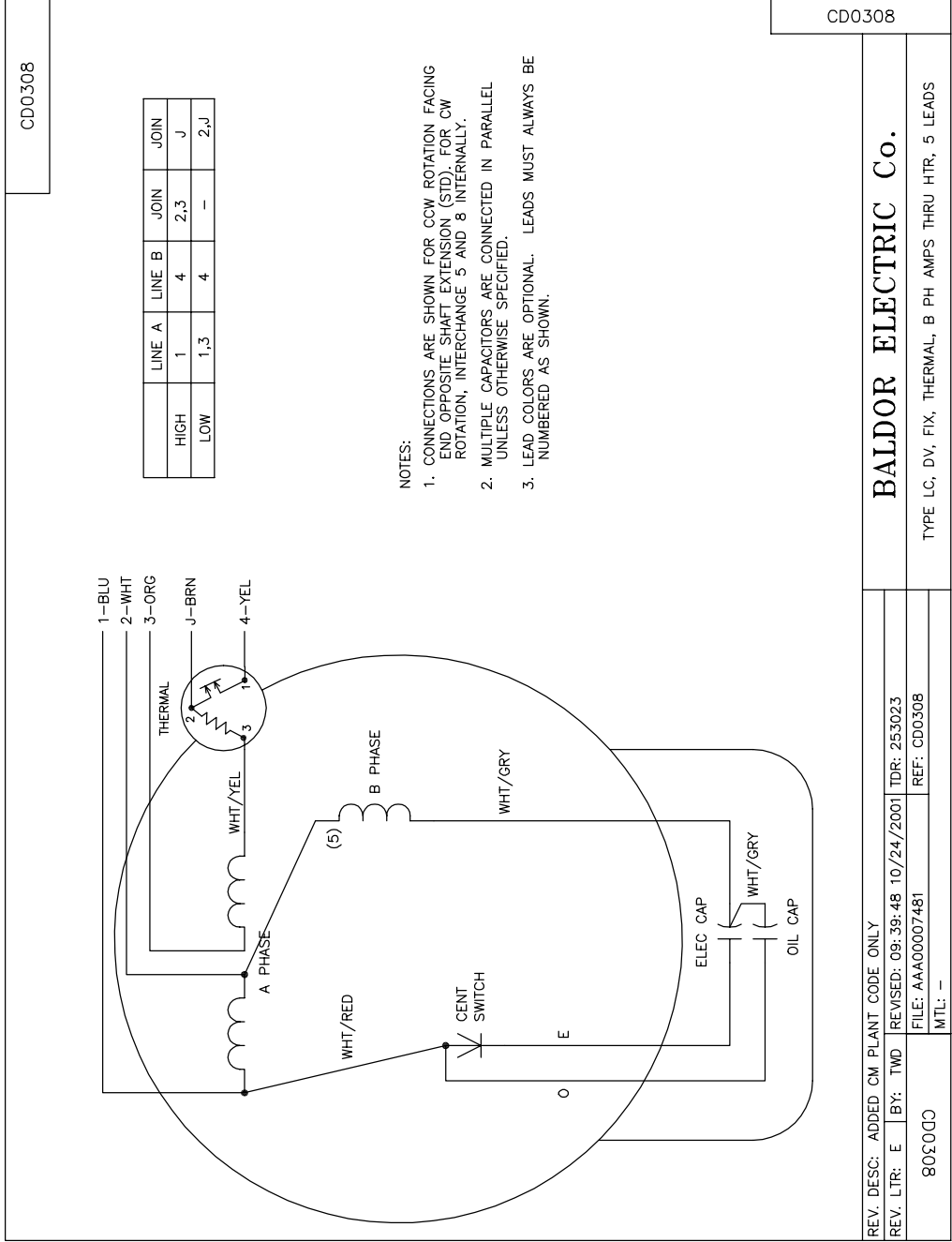

BALDOR ELECTRIC Co.

REV. DESC: ADDED CM PLANT CODE ONLY
 REV. LTR: E BY: TWD REVISED: 09:39:48 10/24/2001 TDR: 253023
 805000 FILE: AA00007481 REF: CD0308
 MTL: -

TYPE LC, DV, FIX, THERMAL, B PH AMPS THRU HTR, 5 LEADS